

SCM-SLB-WBR

WHITE, BLUE AND RED BRACKET MOUNT SPREADER LIGHT



▶ **MODEL #:** SCM-SLB-WBR-WH

▶ **OPERATION**

- When power is applied to the light, the brightness slowly ramps up to full power over approximately 3 seconds
- Toggle power during ramp up to set brightness
- Subsequent power toggles will toggle from blue to red and back to white
- To reset the light, turn off for 10 seconds

▶ **SPECIFICATIONS**

- Power consumption: 2 amps at 12V, 1 amp at 24V
- 10-30V DC input
- IP67 (waterproof)
- Durable glass window

▶ **INSTALLATION**

- Find a suitable location with sufficient clearance for 1/4-20 mounting bolt and routing waterproof cable.
- Connect power and ground.

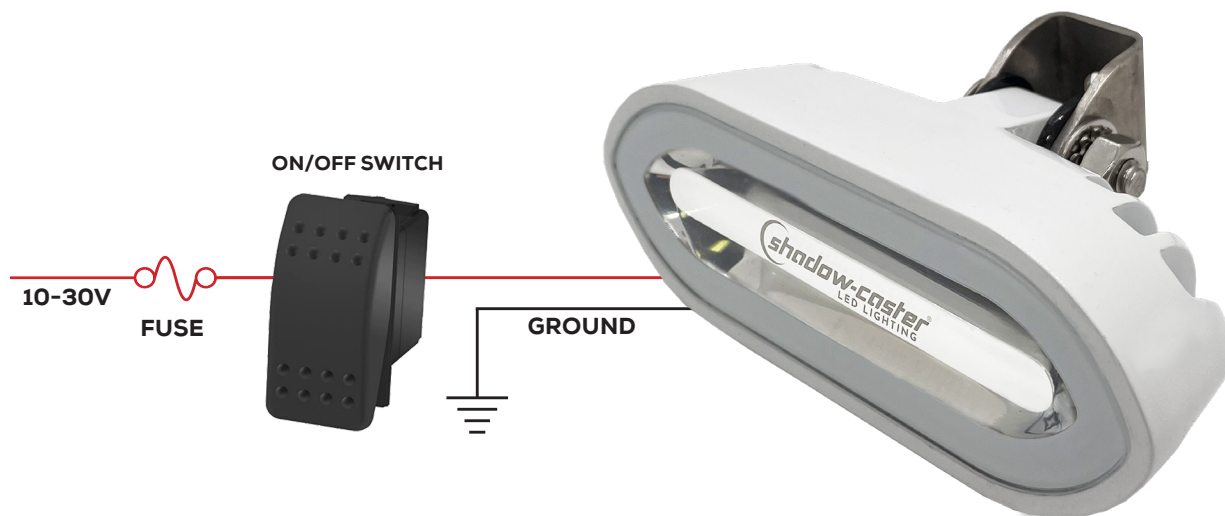

Designed & Manufactured
in Clearwater, FL
© 2022 Shadow-Caster™ LEDs. All Right Reserved.

Shadow-Caster™ LED Lighting | 2060 Calumet Street | Clearwater, FL 33765
p: +1 727.474.2877 e: info@shadow-caster.com w: shadow-caster.com

SCM-SLB-WBR

WHITE, BLUE AND RED BRACKET MOUNT SPREADER LIGHT



DRAWINGS ARE ACTUAL SIZE

TOP VIEW

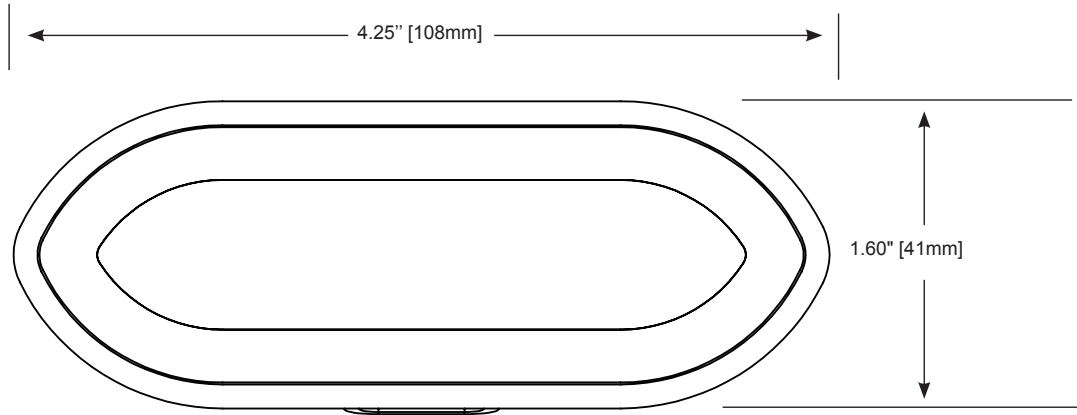

SIDE VIEW

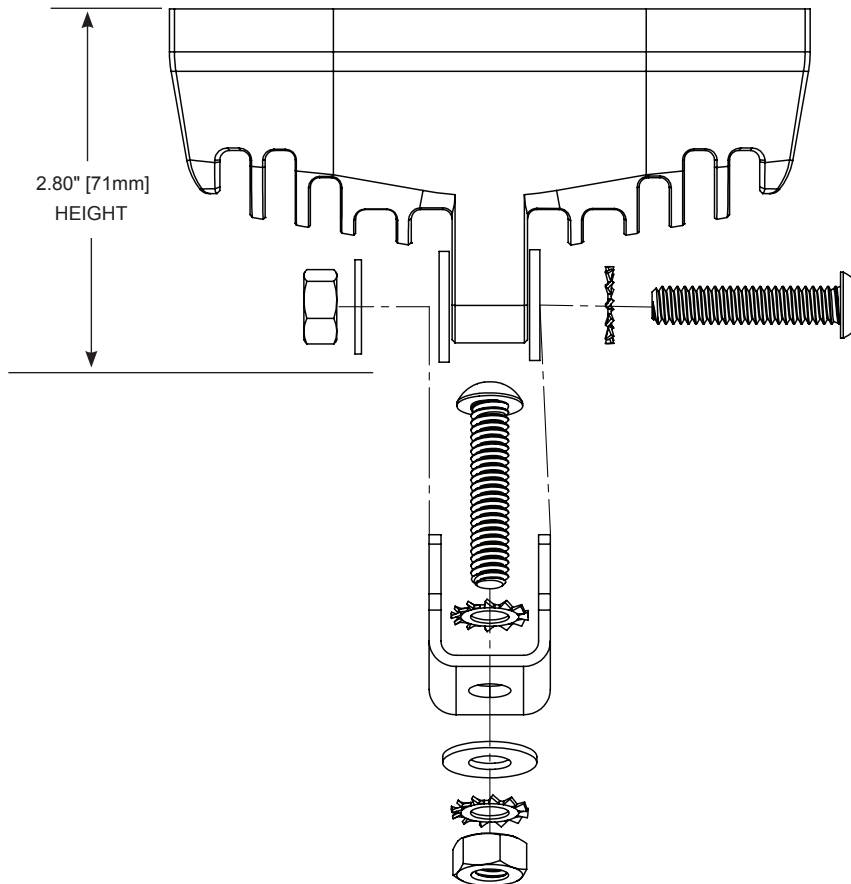

Designed & Manufactured
in Clearwater, FL

© 2022 Shadow-Caster™ LEDs. All Right Reserved.

Shadow-Caster™ LED Lighting | 2060 Calumet Street | Clearwater, FL 33765

p: +1 727.474.2877 e: info@shadow-caster.com w: shadow-caster.com