

# SC3-BZSM SERIES

3" SERIES SURFACE MOUNT UNDERWATER LIGHT



▶ **MODEL #S:** SC3-BB-BZSM • SC3-BW-BZSM • SC3-CC-BZSM • SC3-GW-BZSM

▶ **OPERATION**

**Single color versions:** On and off only

**Power Toggle Control (SC3-CC and SC3-BW):** Step to the next color by quickly turning the power off and then on within 2 seconds. The SC3-CC will go through the following colors: blue, white, green, red, aqua, blue-violet, violet, magenta, yellow, purple, orange, and green-yellow. The SC3-BW will go blue, white then back to blue.

**Shadow-NET™ (SC3-CC only):** Direct Digital Control compatible through your boat's touch screen, push button controller or Shadow-Caster™ app. Shadow NET™ requires connection of orange and yellow Shadow-NET™ wires to a compatible controller.

▶ **INSTALLATION INSTRUCTIONS**

**Please read completely before installation:**

1. Choose mounting location - The lights require water cooling and should be installed on a flat surface area that is below the water line. Also consider the area inside the boat where the wire will enter and make sure it will be accessible to retrieve the wire. It is NOT recommended to mount the lights on hull running surfaces.
2. The template below can be used for finding an appropriate mounting location. Verify that the template matches the mounting holes on the light if using this as a drill template. Make sure you are drilling into a place where you can get to the hole from inside the boat in order to feed wire. Mark center drill location with pencil.
3. Drill a 5/8" diameter hole for the cable in the center hole location only (shown on template).
4. If mounting to an aluminum hull you will need to purchase part number: SCM-GASKET-SC3SM-BR for galvanic isolation to prevent corrosion.
5. Feed the cable through the hull into the boat.
6. With the light against the hull in the location to be mounted, use the actual mounting holes of the light to mark one mounting hole. Drill that hole with an appropriately sized drill (9/64 is typical for #8 screws). Be sure the drill is not oversized or undersized. An undersized hole can cause the screws to break, oversize the hole and the hole will strip. With the light in place thread a screw into the hole. Perform same steps for remaining holes.
7. Place a sufficient amount of marine sealant on the hull around all holes to seal them against the light's base plate.
8. Fill the screw holes with sealant.
9. Use provided screws to mount light to the hull. If alternate screws are used they must be silicon bronze. After mounting wipe off any excess marine sealant around the light. Gently remove any spots with denatured alcohol on a lint free rag or cloth.

▶ **CONNECTIONS**

**Red Wire:** Positive 10-30V DC input. Typical current draw is 2 amps at (12 volt) and 1 amp on a 24 volt system.

**Black Wire:** Common ground

**Orange and Yellow Wire on CC versions only:**

Shadow-NET™ Digital Communications. Connect to a compatible Shadow-NET™ controller. See options such as SCM-LC-PLUS.

**Please Note:** Shadow-NET™ will override power toggle control. For multiple light installations, check the control and power distribution section of our website for more information.

▶ **CARE AND MAINTENANCE**

Clean your Shadow-Caster™ Marine LED lights frequently with a soft bristle brush. We recommend that installed Shadow-Caster™ Marine LED lights be cleaned every 2 weeks for "live in water" boats, and rinsed every time the boat is pulled out of the water to prevent marine growth buildup and bio-fouling. Using cleaners that contain solvents other than alcohol may damage light and potentially void warranty. This includes acetone, acetates, ethers, esters acetates, xylene, amines, hydrocarbons, methyl ethyl ketone (MEK).



Designed & Manufactured in Clearwater, FL  
© 2023 Shadow-Caster™ LEDs. All Right Reserved.

Shadow-Caster™ LED Lighting | 2060 Calumet Street | Clearwater, FL 33765  
p: +1 727.474.2877 e: info@shadow-caster.com w: shadow-caster.com

# SC3-BZSM SERIES

3" SERIES SURFACE MOUNT UNDERWATER LIGHT



## SC3-BZSM MOUNTING

DRAWINGS ARE ACTUAL SIZE

TOP VIEW

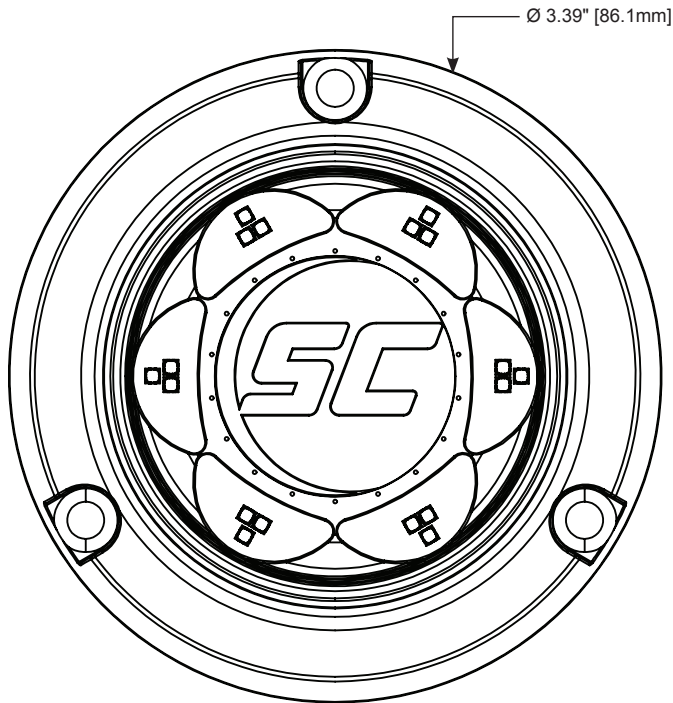

TOP VIEW

MOUNTING HOLE LOCATION

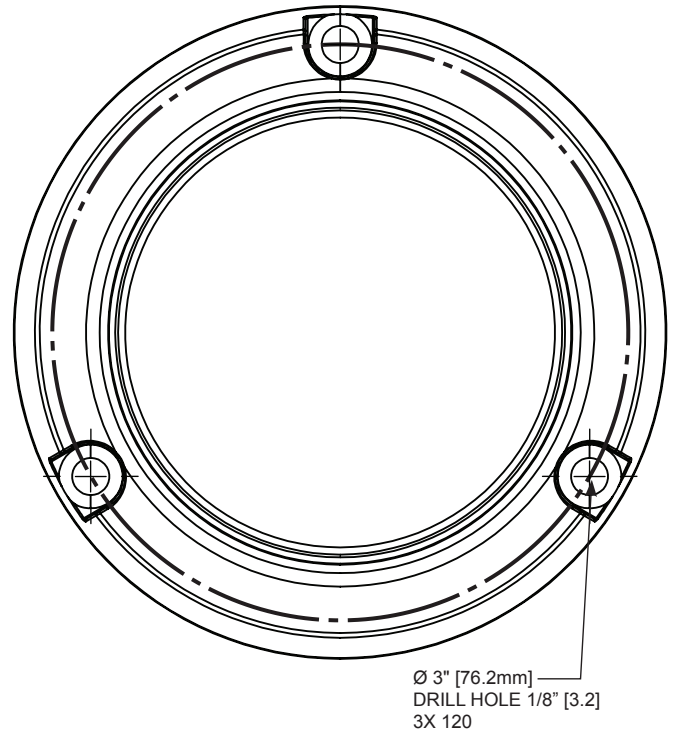

SIDE VIEW

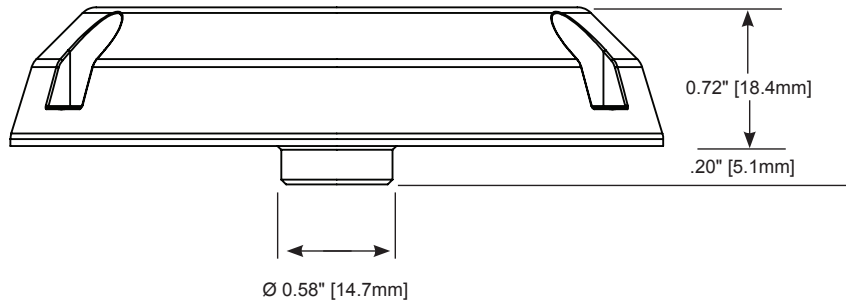

Designed & Manufactured in Clearwater, FL  
© 2023 Shadow-Caster™ LEDs. All Right Reserved.

Shadow-Caster™ LED Lighting | 2060 Calumet Street | Clearwater, FL 33765  
p: +1 727.474.2877 e: info@shadow-caster.com w: shadow-caster.com